

CONVEYOR PULLEY DESIGN

There are many elements to consider during the design of a conveyor pulley. The most important however is the design of the shafts. Other elements that need to be considered are the pulley diameter, the shell, the hubs and the locking elements.

1.0 Shaft design

There are three main factors that influence shaft design. Bending from the tensions on the conveyor belt. Torsion from the drive unit and deflection. The shaft therefore needs to be designed considering all three of these elements.

For the design of the shaft, based on bending and torsion, a max stress is used. This stress varies according to the material that is used for the shaft or according to the max stress allowed by the end user. Typical allowable stresses, for the most commonly used shaft material, are:

- 43 MPa for BS970 070M20 (EN3)
- 55 MPa for BS970 080M40 (EN8)
- 83 MPa for BS970 709M40 (EN19)

For the design according to maximum stress the following needs to be considered:

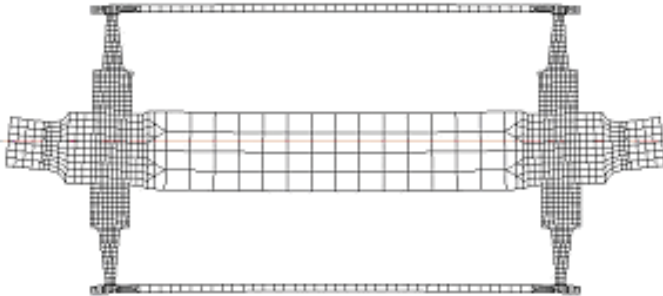

The industry uses additional safety factors for shaft design, as follows:

- Load Factor ($K_b = 1.5$ to 1.75) and;
- Torque Factor ($K_t = 1.25$ to 1.4)

1.1 Calculate torque

$$T_{eff} = T_1 - T_2 \text{ (Calculate effective torsion)}$$

$$T = \frac{T_{eff} \cdot K_t \cdot D}{2} \text{ or } T = \frac{P \cdot 9550 \cdot K_t}{n} \text{ (Calculate absorbed torque)}$$

From the above, use the greater value of torque to input into subsequent calculations.

1.2 Calculate resultant forces

$$\varphi = \frac{2 \cdot \pi (90 - \frac{\beta}{2})}{360} \text{ (Calculate resultant wrap angle)}$$

$$T_{res} = \sqrt{(T_1 \cdot \sin \varphi + T_2 \cdot \sin(-\varphi))^2 + (T_1 \cdot \cos \varphi + T_2 \cdot \cos(-\varphi))^2} \text{ (Calculate resultant torsion)}$$

1.3 Calculate moments

$$M = (\text{Bearing center} - \text{Pulley face}) \cdot \frac{T_{res} \cdot K_b}{4}$$

$$\text{Combined torsion: } T_e = \sqrt{T^2 - M^2}$$

$$\text{Combined bending: } M_e = \frac{1}{2}(M + T_e)$$

1.4 Calculate shaft

To calculate the shaft size from the above, the Guest (equivalent bending) and Rankine (equivalent torsion) formulas need to be considered.

$$\text{Torsion based diameter: } D_g = \sqrt[3]{\frac{16000 \cdot T_e}{\lambda \pi}}$$

$$\text{Bending based diameter: } D_r = \sqrt[3]{\frac{32000 \cdot M_e}{\sigma \pi}}$$

For the above formulas σ and π are taken to be equal since the allowable direct stress (σ) is a fatigue case and the shear stress (λ) is not.

The third calculation determines free shaft deflection limit. This limit ensures that there is no excessive deflection of the shaft at the point where the bearings and the locking elements are fitted. The industry standard is 0.0015 rad to 0.0017 rad max allowable deflection.

$$\text{Deflection based diameter: } D_d = \sqrt[4]{\frac{W \cdot a \cdot L \cdot 16000}{E \cdot \pi \cdot \alpha}}$$

The largest of the three possible diameters should be chosen and then rounded up to the next standard shaft size.

Definitions:

- $P =$ Absorbed power (kW)
- $n =$ Rev / min (rpm)
- $D =$ Pulley diameter (m)
- $\lambda =$ Shear stress (MPa)
- $\sigma =$ Direct stress (MPa)
- $\pi =$ 3.142
- $W =$ Nett tension without K_b (KN)
- $a =$ Bearing center to hub distance (mm)
- $L =$ Hub spacing (mm)
- $E =$ Young's modulus for shaft (N/mm²)
- $\alpha =$ Allowable deflection (radians)
- $\beta =$ Wrap angle (degrees)
- T_{eff} Effective tension (KN)
- T_{res} Resultant tension (KN)

The table below gives a guideline on recommended pulley diameters, standard pulley face widths and bearing centers using belt widths from SABS 1669.

According to SANS 1669	Belt	900	1050	1200	1350	1500	1650	1800	2100	2400
	Face	1050	1200	1350	1500	1700	1850	2000	2300	2600
	Brg Center	1350	1700	1850	2050	2300	2450	2600	2900	3200

Pulley Diameter	Shaft Dia/ Pulley Dia	Resultant tensions (kN)								
200	100 / 315	21	18	16	13	10	10	9	8	7
250	110 / 400	30	26	23	19	16	14	13	12	10
315	120 / 400	45	37	33	27	22	20	19	16	14
400	130 / 400	60	51	45	37	30	28	26	22	19
500	140 / 500	80	70	60	50	41	37	35	30	25
630	150 / 500	100	90	80	66	54	49	45	40	35
800	160 / 500	119	119	105	86	70	64	60	50	45
1000	170 / 630	144	144	133	110	88	81	75	65	55
1250	180 / 630	170	170	165	138	112	100	95	82	70
	190 / 630	200	200	200	170	138	130	120	100	90
	200 / 630	235	235	235	210	170	155	145	125	110
	220 / 800	313	313	313	285	250	230	210	185	160
	240 / 800	405	405	405	370	340	320	300	260	230
	260 / 800	515	515	515	470	430	430	410	360	310
	280 / 1000	640	640	640	585	535	535	535	480	420
	300 / 1000	790	790	790	720	660	660	660	640	560

The recommended shaft sizes are calculated using 55MPa stress, 0.0015 rad deflection and no torque. This table is to be used as a guideline only.

2.0 Pulley design

There are various factors influencing the pulley diameter. The pulley diameter is mainly determined by the conveyor belt class, but the required shaft diameter also influences the diameter. A golden rule for the pulleys diameter is that it should be at least three times the diameter of the shaft.

2.1 Pulley Types

There are two main types of pulleys i.e. the Turbine pulley and the T-Bottom Pulley. In both these types of pulleys the shaft is removable for easy maintenance.

The **Turbine Pulley** is well suited for low to medium duty applications with a hub designed to allow for flexing, thus preventing high stresses on the locking assemblies or welds.

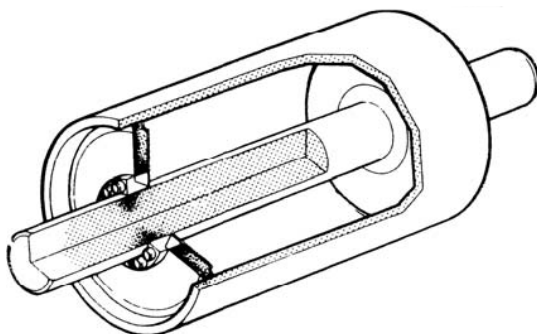

The **T-Bottom Pulley** is normally used for heavy duty applications with shaft diameters of 200mm and bigger. The main feature of this construction is a face welded pulley and thus the shell to hub weld is moved out of the high stressed area at the end plate

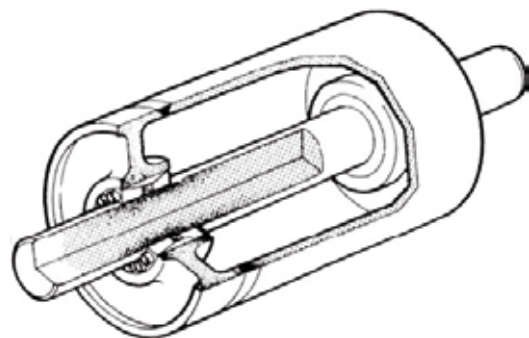

2.2 Pulley crowning

- **Full Crown:** From the centre line of the pulley with a ratio of 1:100
- **Strip Crown:** Crown from the first and last third of the pulley face with a ratio of 1:100

Crowning is normally only done on specific request.

2.3 Lagging

Various types of lagging can be applied to the pulley i.e. rubber lagging, flameproof (neoprene) lagging or ceramic lagging.